

# Category A & B Shipping Examples

## Category A Infectious Substances

Category A infectious substances are capable of causing permanent disability, life threatening or fatal disease to humans or animals when exposure to them occurs. Category A infectious substances have two shipping names: "Infectious substances, affecting humans" (UN 2814) or "Infectious substances, affecting animals" (UN 2900).

### Packaging

Category A infectious substances must be triple packaged and compliant with IATA Packing Instruction 602 diagrammed below. The maximum quantity of Category A infectious substance that can be shipped by air in one package is 4 L or 4 kg. The maximum allowable quantity on passenger aircraft is 50 ml or 50 g.

### Labeling

The outer container of all Category A infectious substance packages must display the following on two opposite sides:

- Sender's name and address
- Recipient's name and address
- Infectious substance label
- Proper shipping name, UN number, and net quantity of infectious substance
- Name and telephone number of person responsible for shipment
- Cargo Aircraft Only label when shipping over 50 ml or 50 g
- Class 9 label, including UN 1845, and net weight if packaged with dry ice

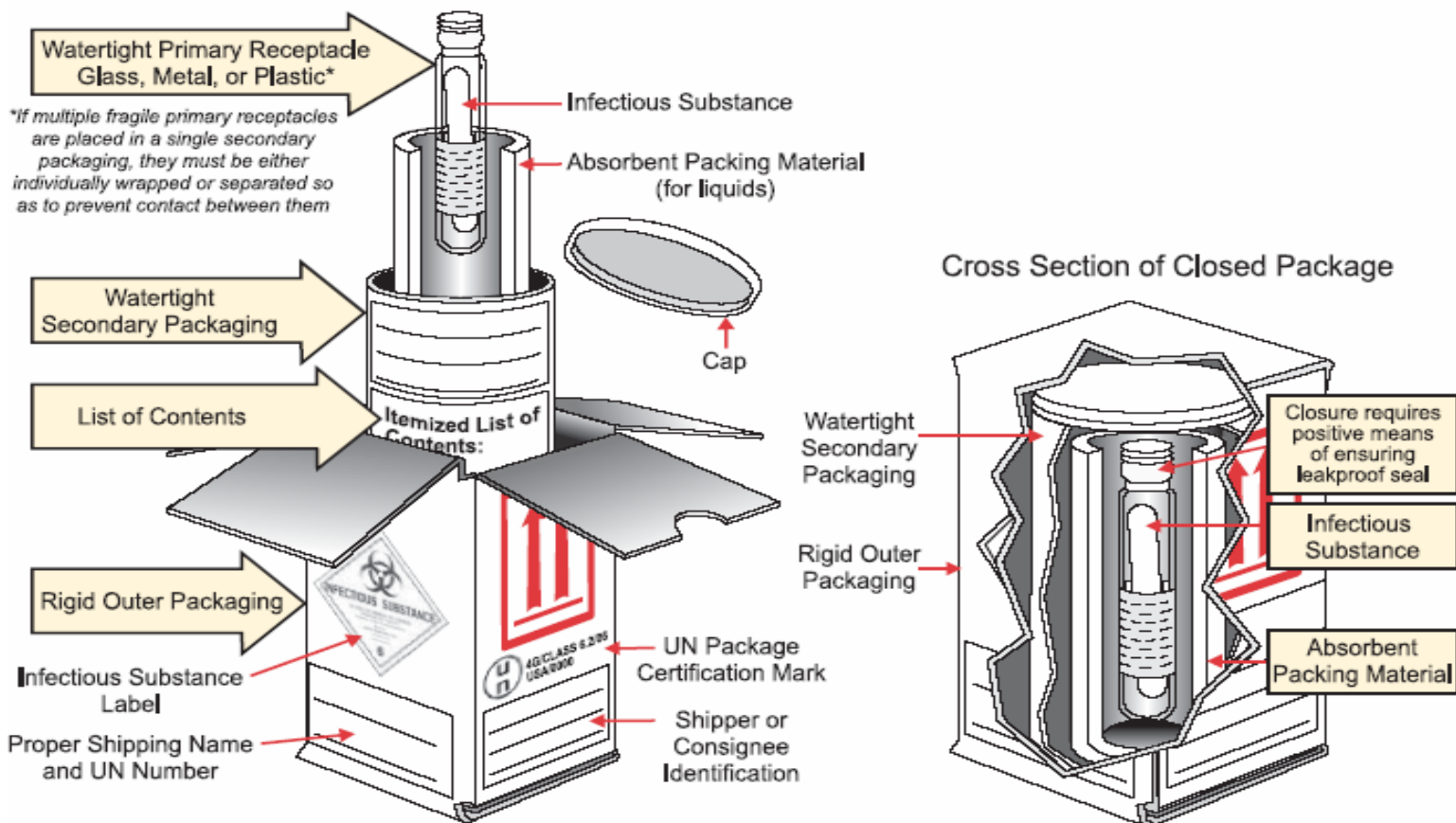

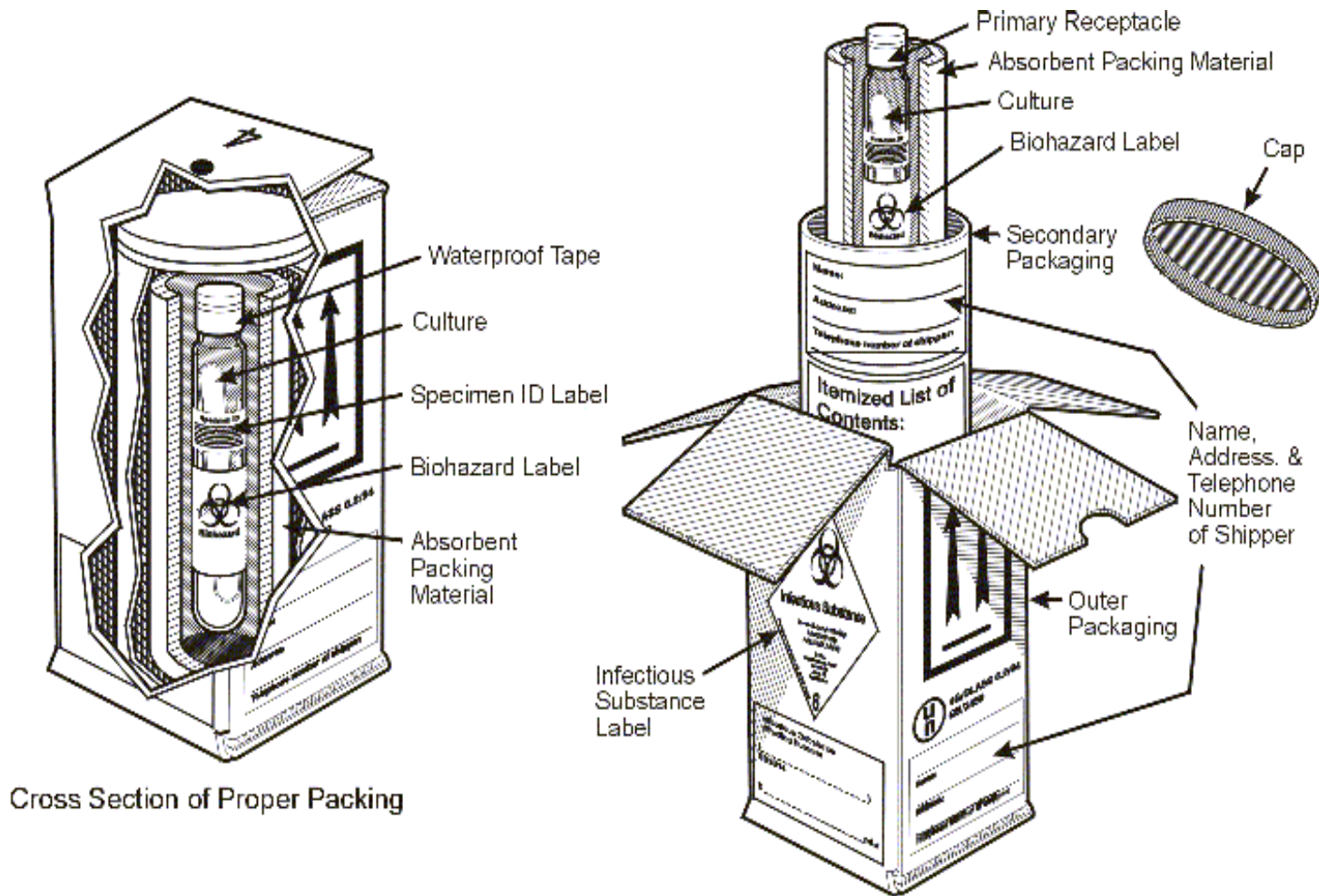

Cross Section of Proper Packing

## Category B Infectious Substances

Category B infectious substances are infectious but do not meet the criteria for Category A. Category B infectious substances have the proper shipping name "Biological Substance, Category B" and the identification number UN 3373.

### Packaging

Category B infectious substances must be triple packaged and compliant with IATA Packing Instruction 650 detailed below. The maximum quantity for a primary receptacle is 500 ml or 500g and outer packaging must not contain more than 4 L or 4 kg.

### Labeling

The outer container of all Category B infectious substance packages must display the following on two opposite sides:

- Sender's name and address
- Recipient's name and address
- The words "Biological Substance, Category B"
- UN 3373 label
- Class 9 label, including UN 1845, and net weight if packaged with dry ice

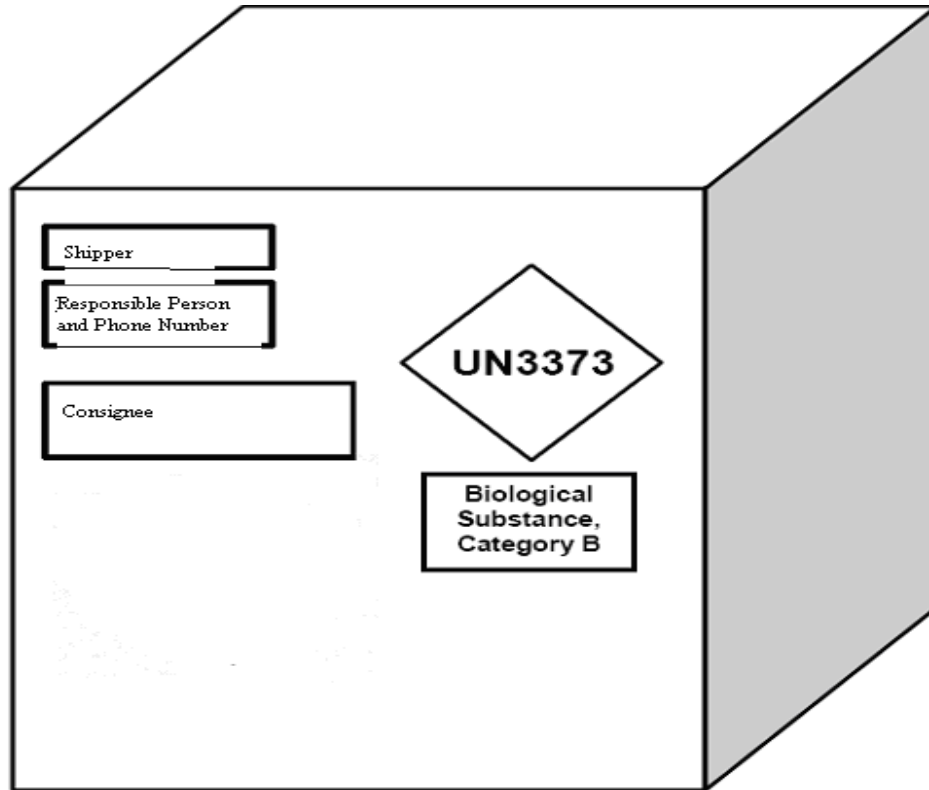
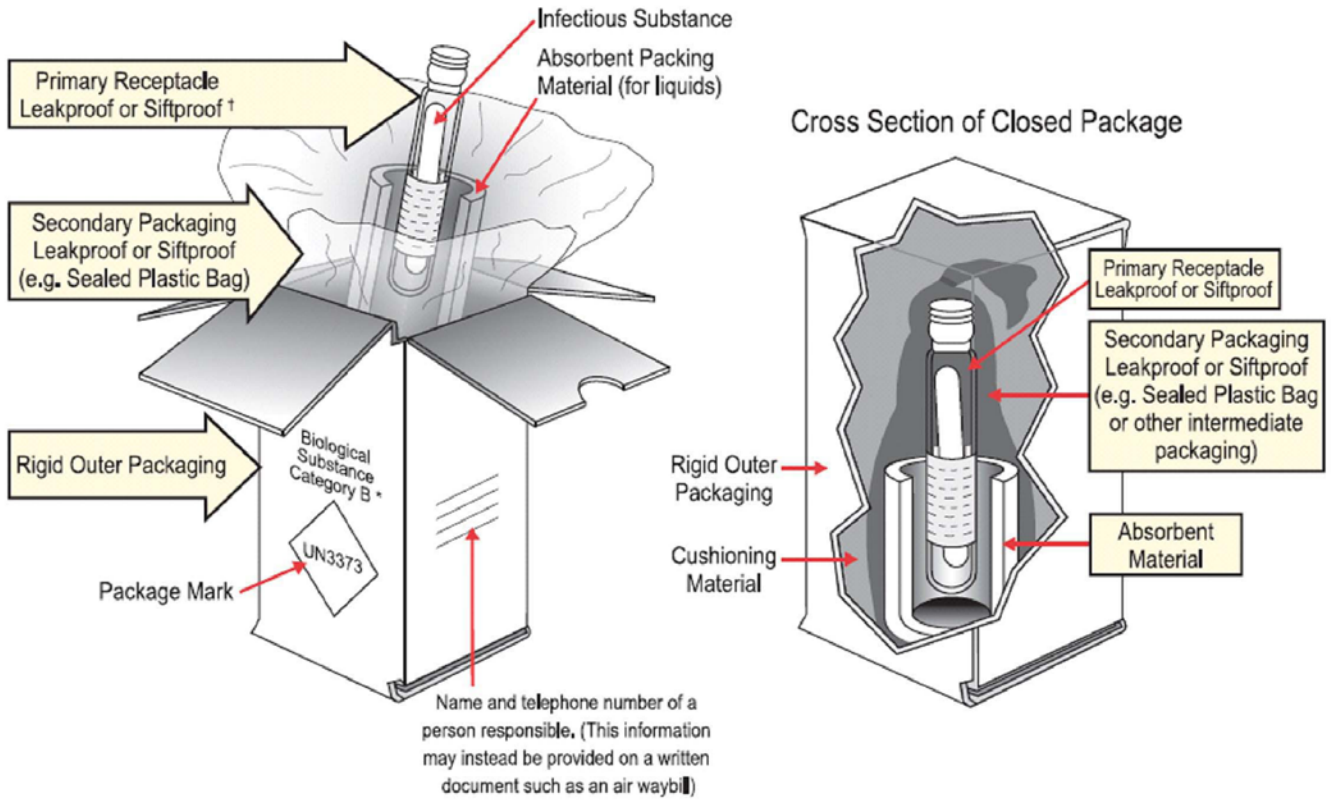

A completely labeled outer package. The primary container inside the package contains a Biological Substance, Category B substance and is packed according to PI 650.